

Electrical Components

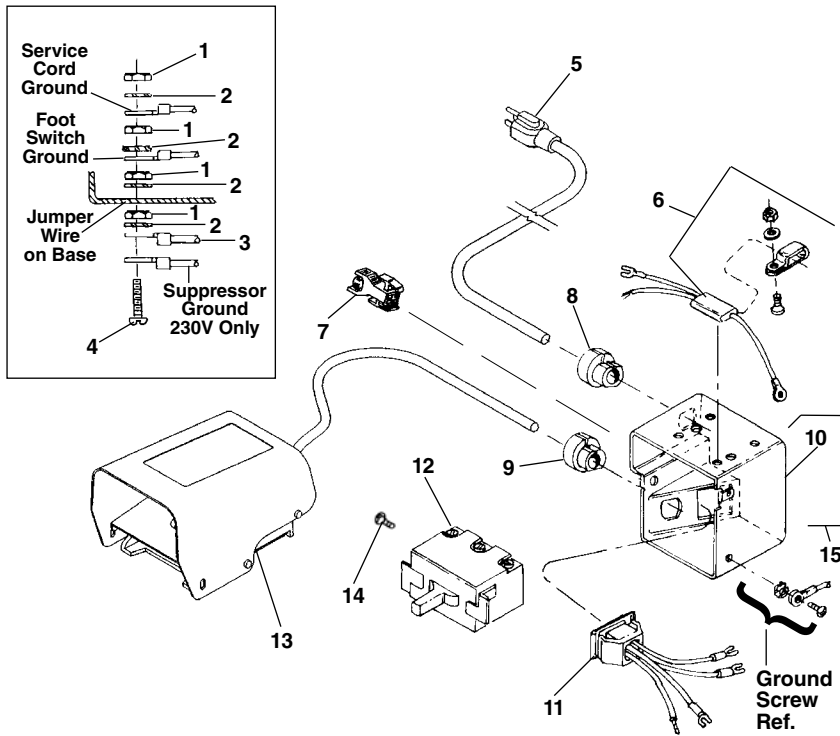

NOTE: Order parts by Catalog Number only. DO NOT order by Reference Number.

Ref. No.	Catalog No.	Description
1	44695	Hex Nut #10 - 24 (4)
2	46985	Ext. Tooth Washer #10 (4)
3	85925	Jumper Wire
4	92455	Screw #10 - 24 x 3/4"
5	46740	Power Cord w/Plug (115V)
	46410	Power Cord w/Plug (230V)
	75045	Power Cordless Plug (230V Europe/S. Africa)
6	46320	Suppressor Kit (230V Europe)
	99170	Suppressor (230V S. Africa)
7	50552	Plug
8	46735	Cord Grommet
	46730	Cord Grommet (230V Europe/S. Africa)
9	46735	Cord Grommet
10	50612	Switch Box
11	50617	Outlet Jumper Assembly
12	44505	Switch
13	36642	B-294 Foot Switch
14	44180	Screw
15	91187	Switch Box Kit (Includes Ref. Nos. 7-11)

Model "A" Pump

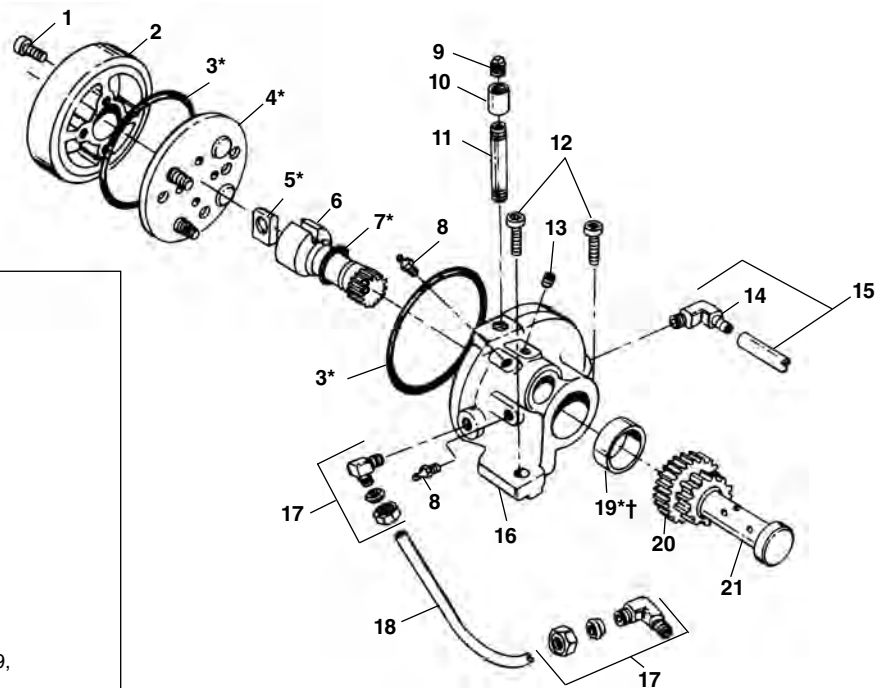

Ref. No.	Catalog No.	Description
1	46770	Screw #10-32 x 1" SHCS (4)
2	46350	Cover
3*	44650	O-Ring (2)
4*	46645	Valve Assembly
5*	47100	Rotor Blade
6	46355	Pinion Shaft
7*	44645	O-Ring
8	46860	Grease Fitting
9	46815	Pipe Plug
10	89725	Coupling
11	89730	Nipple
12	46750	Screw 3/8"-16 x 1" SHCS (2)
13	44455	Set Screw 5/16" x 3/8"
14	87945	90° Fitting
15	75065	Intake Line
16	43470	Pump Body (Incls. Ref. Nos. 3, 8, 16, 19, Roller Bearing)
17	46840	90° Fitting (2)
18	44105	Feed Line
19*†	46715	Oil Seal
20	44350	Idler Gear
21	44345	Gear Shaft
—	91055	Repair Kit (Includes items marked with *)

†Service Note: When replacing Oil Seal, open side should face towards outside of Pump Body. Use care in installing Seal so that lip is not damaged.